

QSA-81000, Sink System w/ Enclosure

One Station Quartz

Sink Location

Determine the appropriate wall location for the Lavatory System. Refer to original spec sheets for correct placement of electrical and plumbing locations. If wall is not load bearing, a carrier may be required behind the wall. Refer to the appropriate Rough-In diagram for Lavatory System dimensions. Prior to Lavatory System installation, electric wiring, water supply and drain must be installed.

SLOAN® LIMITED WARRANTY SUMMARY

Sloan Valve Company ("Sloan"), warrants its products against defects in materials and workmanship, excluding damage caused by matters beyond Sloan's reasonable control. Instructions for filing claims can be found in the Limited Warranty which can be obtained at www.sloan.com or by requesting a free copy by telephone at 888.756.2614. Sloan will repair or replace your defective product, or provide a refund, as your exclusive remedy. This is only a general summary of Sloan's Limited Warranty so it is important to note that the specific terms, conditions, limitations and exclusions, including the duration of warranty coverage for your particular Sloan product, are contained in the actual Sloan Limited Warranty. The Limited Warranty is subject to applicable laws in your country, state, province or other jurisdiction—and disputes arising under the Limited Warranty are to be resolved by binding arbitration unless you provide Sloan with an opt-out notice no later than 30 days after your purchase date. In case of a conflict with this summary, the terms and conditions set forth in the complete Limited Warranty will prevail

Components

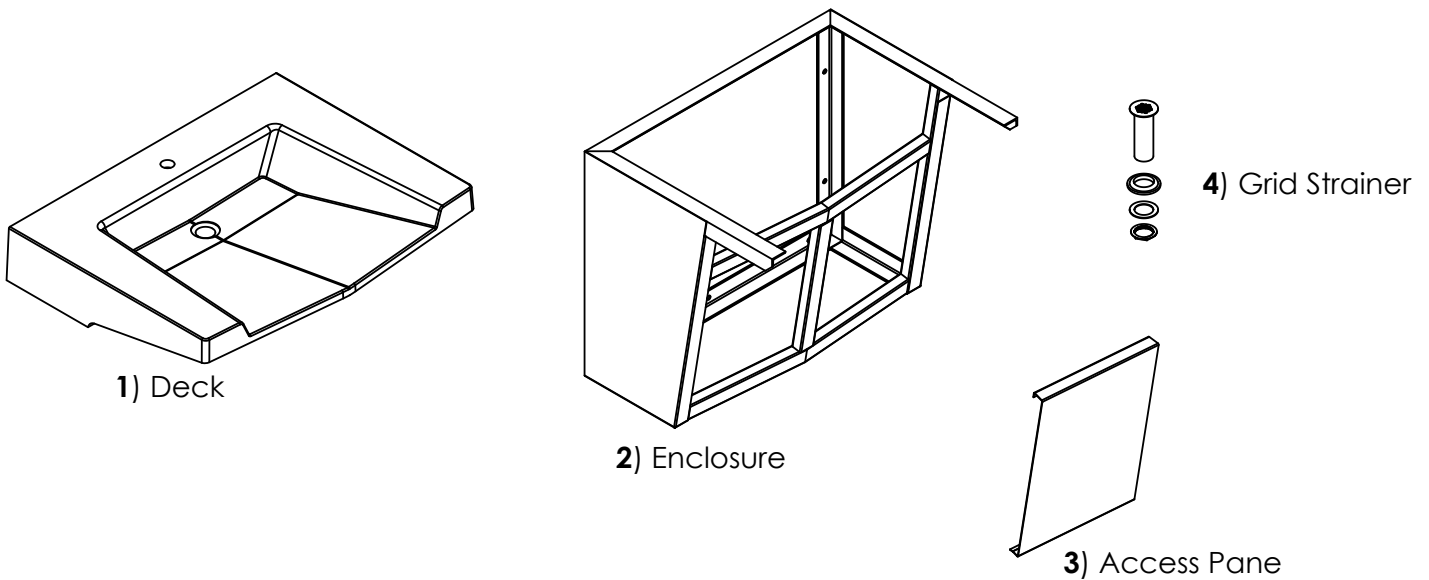

Components List

Description	Item Number	Quantity
QSA-81000, One Station, Deck	1	1
Enclosure	2	1
Access Panel	3	2
Grid Strainer	4	1