

QSGR-82000, Sink System w/ Enclosure

Two Station Quartz

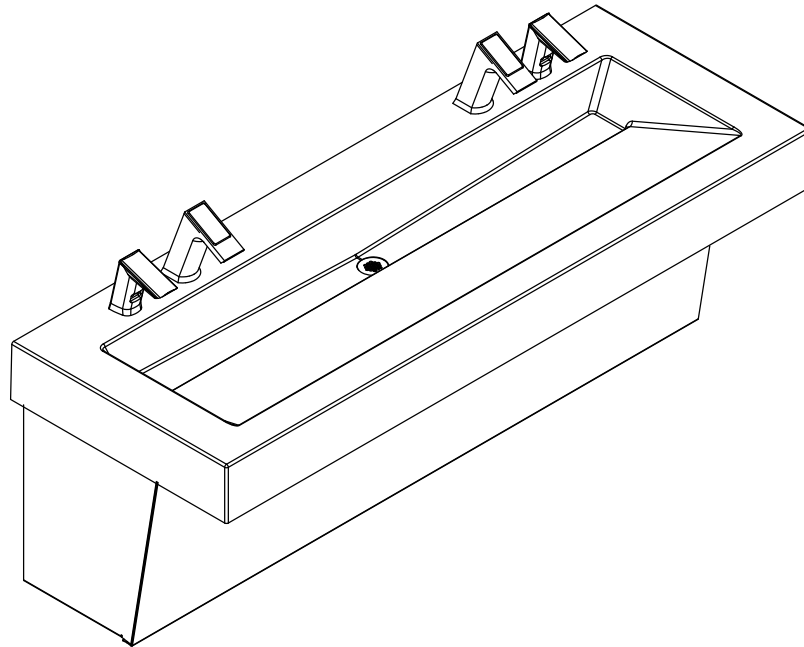

Note: Water and soap components are shown for reference only and may not depict actual components.

Important



Read this entire installation manual to ensure proper installation. When finished with the installation, file this manual with the owner or maintenance department. Compliance and conformity to local codes and ordinances is the responsibility of the installers.



Separate parts from packaging and make sure all parts are accounted for before discarding any packaging material. If any parts are missing, do not begin installation until all parts are obtained.



Make sure that all water supply lines have been flushed and completely turned off before starting the installation. Debris in supply lines can cause valves to malfunction.



Turn off electrical power to the electrical outlets, then unplug units prior to installation. Electrical power **MUST** remain off until installation is complete.



Installers hardware must be appropriate for wall construction. Wall anchors and mounting fasteners **MUST** have a minimum pull-out rating of 1,000 lbs.



For standard height mounting, **DO NOT** exceed the recommended 34 inch distance from the top of the lav deck to the finished floor. To meet ADA requirements the lav deck cannot not exceed the 34 inch maximum height dimension.

Tools and Supplies Required for Installation

- Electric drill for drilling anchor holes.
- Standard sockets, basin wrench, and open end wrench set for installing anchoring fasteners and faucets.
- Pipe wrench for installing drain lines.
- Phillips and straight blade screwdrivers.
- Tubing cutter
- Level
- Carpenter's square
- Caulk gun
- 1/2" NPT hot/cold or tempered supply piping
- 1 1/2" NPT drain piping including p-trap
- Adhesive: Loctite® PL Premium® FAST GRAB Polyurethane Construction Adhesive
- 110 volt GFCI protected electrical outlet for 100-120 VAC plug-in transformer
- Screen filter(s) included with faucet(s)
- Backing supplied by others to meet local codes

Prior to Installation

CAUTION

- ADEQUATE STRUCTURAL SUPPORT IN OR BEHIND THE WALL IS REQUIRED. REFER TO THE APPROPRIATE ROUGH-IN DIAGRAM FOR DRY WEIGHT OF SINK.
- ALL ELECTRICAL WIRING IS TO BE INSTALLED IN ACCORDANCE WITH NATIONAL/LOCAL CODES AND REGULATIONS. ELECTRICAL OUTLETS SHOULD BE RECESSED AND INSTALLED PRIOR TO INSTALLATION.
- ALL PLUMBING SHOULD BE INSTALLED IN ACCORDANCE WITH APPLICABLE CODES AND REGULATIONS.
- BEFORE CONNECTING FLEX HOSES TO SUPPLY STOPS, FLUSH ALL WATER LINES UNTIL WATER IS CLEAR.
- HOT AND COLD WATER SUPPLY LINES/TEMPERED SUPPLY LINE AND DRAIN LINES. RECOMMENDED TO HAVE CONTROL STOPS ON WATER SUPPLY LINES IN PLACE PRIOR TO INSTALLATION.

Sink Location

Determine the appropriate wall location for the Lavatory System. Refer to original spec sheets for correct placement of electrical and plumbing locations. If wall is not load bearing, a carrier may be required behind the wall. Refer to the appropriate Rough-In diagram for Lavatory System dimensions. Prior to Lavatory System installation, electric wiring, water supply and drain must be installed.

Limited Warranty

Sloan® Limited Warranty Summary

Sloan Valve Company ("Sloan"), warrants its products against defects in materials and workmanship, excluding damage caused by matters beyond Sloan's reasonable control. Instructions for filing claims can be found in the Limited Warranty which can be obtained at www.sloan.com or by requesting a free copy by telephone at 888.756.2614. Sloan will repair or replace your defective product, or provide a refund, as your exclusive remedy. This is only a general summary of Sloan's Limited Warranty so it is important to note that the specific terms, conditions, limitations and exclusions, including the duration of warranty coverage for your particular Sloan product, are contained in the actual Sloan Limited Warranty. The Limited Warranty is subject to applicable laws in your country, state, province or other jurisdiction—and disputes arising under the Limited Warranty are to be resolved by binding arbitration unless you provide Sloan with an opt-out notice no later than 30 days after your purchase date. In case of a conflict with this summary, the terms and conditions set forth in the complete Limited Warranty will prevail

Components

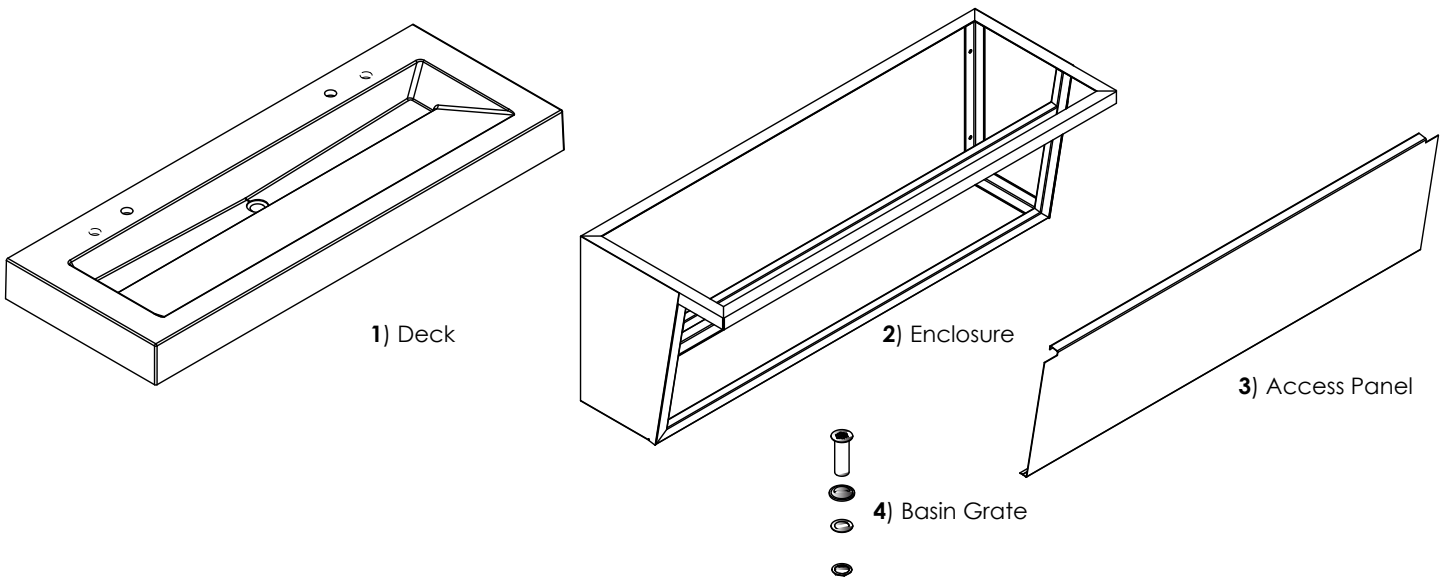

Components List

Description	Item Number	Quantity
QSGR-81000, Two Station, Deck	1	1
Enclosure	2	1
Access Panel	3	1
Grid Strainer	4	1

Figure 1

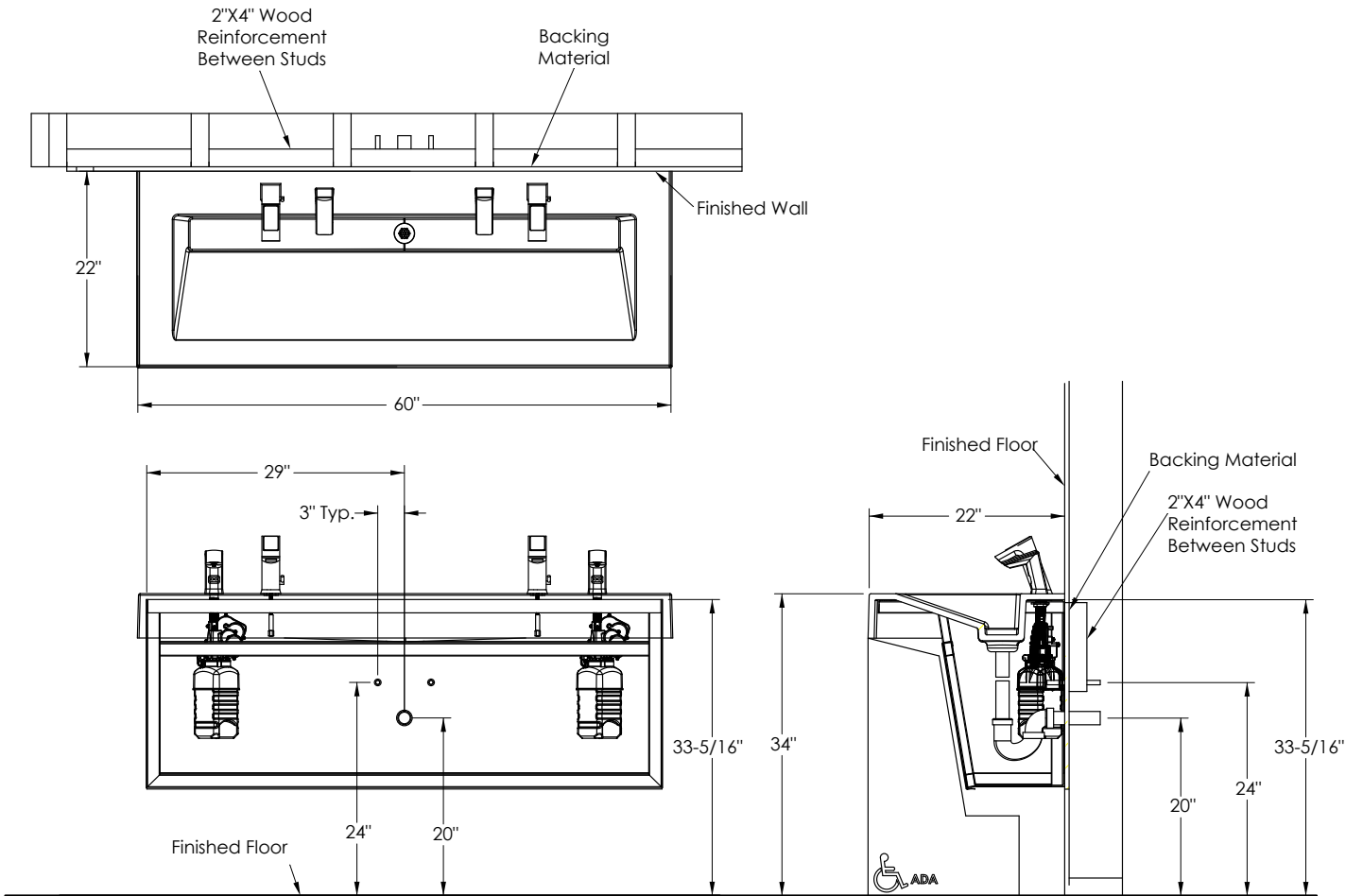

Note: Backing material should equal thickness of drywall, 1/2" min.

Backing and Enclosure Installation

Figure 2

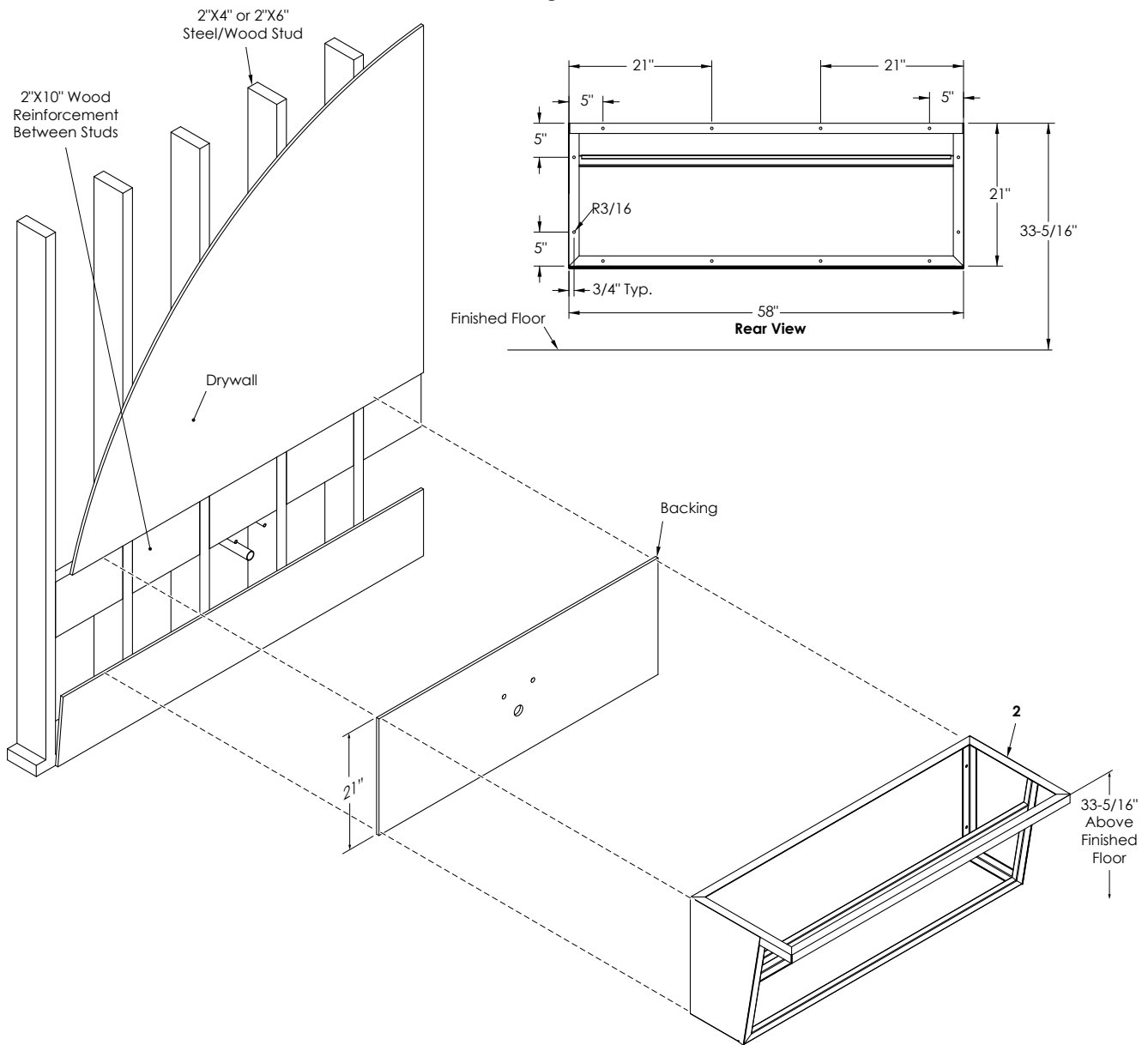

Notes:

- Due to manufacturer tolerances, all dimensions are for reference only.
- Enclosure must be shimmed to wall to make sure proper leveling and straightness.
- Wood 2"X10" may need to be notched to allow clearance for electrical box and plumbing. DO NOT cut wall support studs.

1. Install Backing (Figure 2) onto wall studs.

Note: Backing supplied by others to meet local codes.

- If drywall is present, refer to rough-in, (Figure 2), measure outer dimensions of Enclosure (2) and cut out drywall window.
- Remove drywall window.
- Pre-drill/cut holes for plumbing and electrical.
- Install backing into cutout drywall window.

2. Refer to the template in (Figure 2), mount the Enclosure (2) to the backing. Ensure that Enclosure (2) is level and the proper distance from the floor.

Note: Anchor Enclosure to wall using 1,000 lb pull out mounting fasteners for 3/8" holes (not supplied).

- Using mounting fasteners secure Enclosure (2) onto backing, making sure that the top of Enclosure (2) is 33 5/16 inches above finished floor. (ADA specifications)

Faucet Installation

Notes:

- For ease of deck installation, leave the deck lying on its front (if no bag hooks are installed) or lying on its back and install component spouts.
- Components shown for reference only.

Figure 3

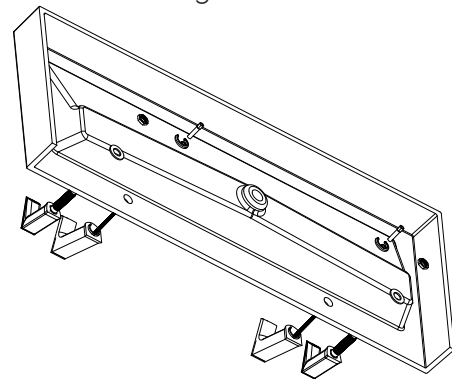

3. Install faucet (Figure 3) and optional soap dispenser onto sink according to manufacturer's instructions.

Sink Installation

Figure 4

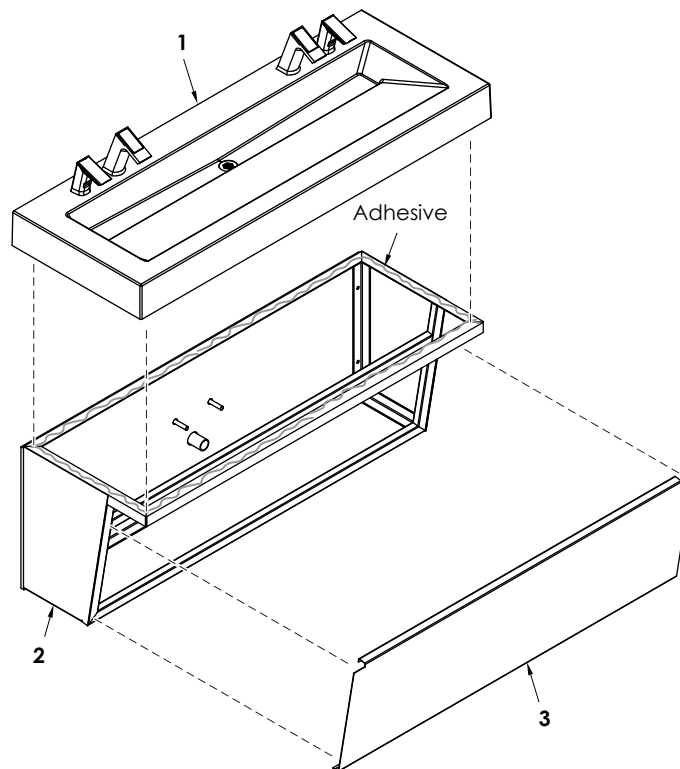

4. Install Deck (1, Figure 4) onto Enclosure (2).
 - a. Apply adhesive (not supplied) to the top of Enclosure (2).
 - b. Lower Deck (1) onto Enclosure (2). Shim all gaps between Enclosure (2) and Deck (1).
 - c. Install all water connections and drain lines.
5. Remove any and all protective tape and/or wrap. Attach Access Panel (3) on Enclosure (2).

End of Installation Instructions