

Optima Plus® Flushometers

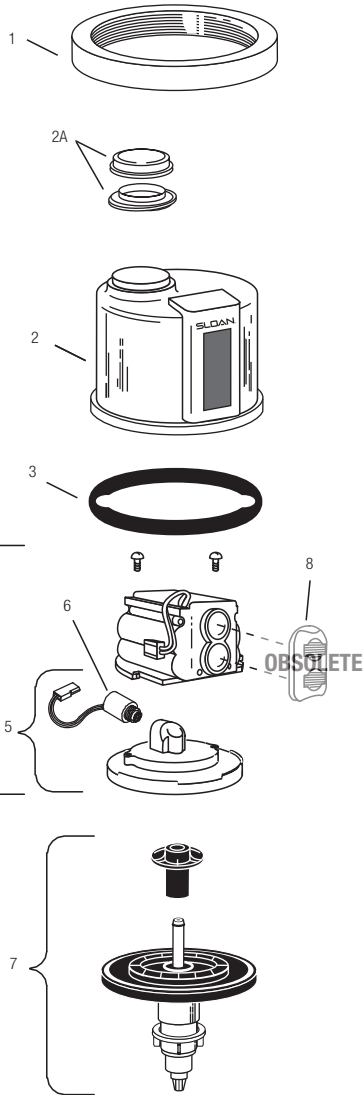

OPTIMA
plus®

Sensor Flushometers



For all Optima Plus® produced from 1992 – 2003 and Regal Pro® Optima Plus® produced after May, 2003.

The Optima Plus® is currently being phased out and will become obsolete at some point in the future. Some repair parts may not be available. See the G2 Optima Plus® flushometer page 61 for current parts.

SENSOR MODULE COMPONENT PARTS

Item No.	Code No.	Part No.	Description
1.	0325804	EBV-14	Locking Ring
	3325524	EBV-31-A	Locking Ring for Zurn Valve Bodies
2.	3325013	EBV-60-A	Metal Cover Assembly with Override Button (Water Closet)
	3325016	EBV-1033-A	Metal Cover Assembly w/Override Button for Zurn Valve Body (Water Closet)
2A.	3325055	EBV-1042-A	Replacement Override Button Kit for plastic covers (Old Style)
3.	5325011	EBV-67	Cover Gasket — 12 per package
4.	SEE CHART PAGE 63 — ELECTRONIC MODULE		
5.	0325814	EBV-21-A	Inside Cover Assembly (Includes Solenoid)
6.	3325462	EBV-144-A	Isolated Solenoid Operator †
7.	SEE CHART PAGE 64 — Flex Tube Diaphragm Kit		
8.	3325537	EBV-46-A	Beam Deflector ‡ — OBSOLETE

† The new EBV-144-A solenoid replaces the solenoid used with the old style black EBV-26-A modules only. For blue EBV-146-A-U or EBV-146-A-C G2 modules, use the EBV-136-A solenoid operator. Refer to Page 65 for instructions regarding solenoid replacement.

‡ Beam deflectors are for use on black, old style modules. They are not required (and will not work) on Blue G2 modules.

