

SMO Side Mount Flushometer Single-flush

Battery powered, sensor activated retrofit unit for exposed closet and urinal flushometers.



PARTS LIST

Item No.	Code No.	Part No.	Description
1.	0325105	EBV-89-A	Side Mount Operator for Water Closets (Toilets) and Urinals
2.	0301139	A-31	Gasket
3.	0325148	EBV-118	Lens
4.	0325153	EBV-123	Button repair kit
5.	0325150	EBV-120	Wrench
6.	0325157	EBV-127	Metal Cover Closet w/OR
7.	—	EBV-119	Allen Wrench 3mm security hex
8.	0325192	EBV-157-A	Handle Adapter Kit (Includes Green "L" Gasket) for GEM-2®
9.	5302297	B-39	Handle Seal (pack of 12)
10.	5325428	EBV-584	Gasket (Green) GEM SMO (pack of 5)

Note: Battery door screw is not an available part. Use M4-0.7 x 12 mm screw as suitable replacement.

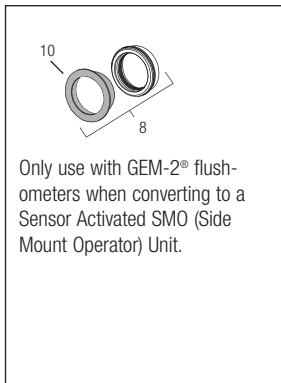
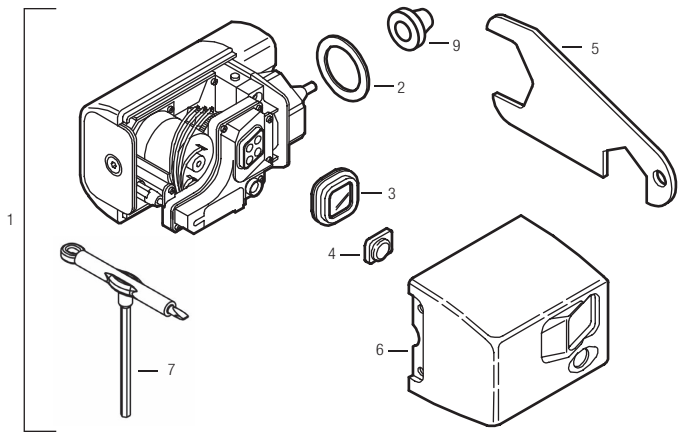

SMO Side Mount Flushometer Single-flush

TO CHANGE ACTIVATION DISTANCE FOR THE OBJECT LOCK SENSOR

1. Remove battery compartment tray as shown at right.
2. Remove cover as shown at right.
3. Remove sensor adjuster tool as shown at right. Replace battery compartment in Side Mount Operator to activate unit.
4. Press sensor range reset button as shown below (the green L.E.D. will flash continuously when it has an object in view for the seven minute reset period).
5. Stand at desired activation distance.
6. Use sensor adjuster tool (see below) and turn Distance Adjustment Screw all the way down and then turn slowly up until green L.E.D. begins to flash.
7. Ensure Object Lock Sensor is not detecting stall door or wall by closing door, stepping out of sensor path and making sure green L.E.D. is not flashing. If sensor locks onto door or wall, unit will not flush properly. Shorten activation distance.
8. Remove battery compartment, replace sensor adjuster tool and cover. Replace battery compartment tray to reactivate Side Mount Operator unit.
9. After 7 minute start-up sequence, the green L.E.D. will flash only 3 times when a user is in view (after a 5 second delay).

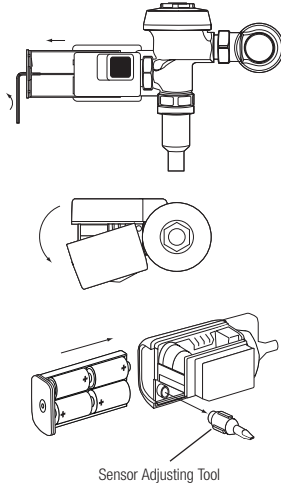

TROUBLESHOOTING GUIDE

- 1. Green L.E.D. (light) flashes 3 times when there are no users**
 - A. Front of Object Lock Sensor is covered or Object Lock Sensor is set too far out, registering the opposite wall or door as a user. Remove item covering sensor or adjust Object Lock Sensor activation distance. (See section – Adjusting Your Side Mount Operator)
- 2. Green L.E.D. (light) flashes continuously when Object Lock Sensor is activated by a user**
 - A. Side Mount Operator unit is in 7 minute start up mode (when first activated) or Sensor Range Reset Button has been depressed. Green L.E.D. (light) will flash only 3 times acknowledging a user is in view after the 7 minute start up mode
- 3. Orange L.E.D. (light) flashes**
 - A. Batteries need replacing. Replace batteries.
- 4. Not enough water to fixture or too much water to fixture**
 - A. Diaphragm damaged or valve control stop improperly adjusted. Replace diaphragm and/or adjust valve control stop
- 5. Valve will not operate**
 - A. Object Lock Sensor range set too close to Side Mount Operator, batteries are dead, or water supply is turned off. Adjust Object Lock Sensor – Replace batteries – Turn water on.
- 6. Valve does not shut off**
 - A. Dirt or debris preventing diaphragm from functioning properly. Remove dirt or debris, consult valve manufacturer's directions.
- 7. Valve does not flush even after Object Lock Sensor has been adjusted**
 - A. Dead batteries. Replace batteries.

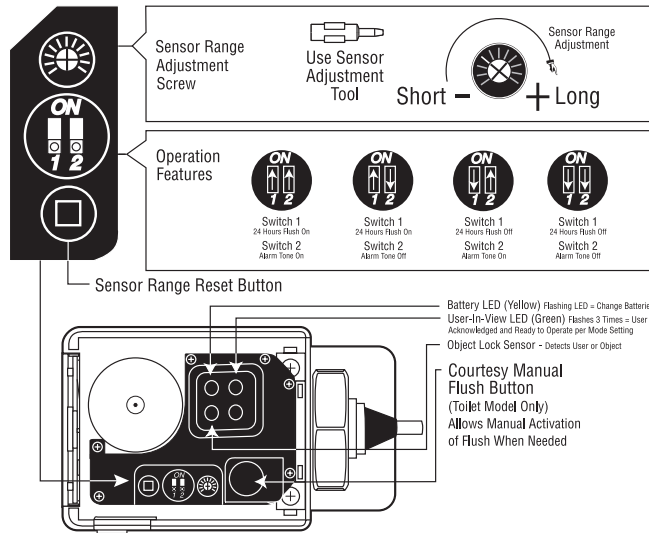

CARE AND CLEANING OF CHROME AND SPECIAL FINISHES

DO NOT USE abrasive or chemical cleaners to clean flushometers as they may dull the luster and attack the chrome or special decorative finishes. Use **ONLY** mild soap and water, then wipe dry with clean cloth or towel.

While cleaning the bathroom tile, the flushometer should be protected from any splattering of cleaner. Acids and cleaning fluids can discolor or remove chrome plating.

When assistance is required, please contact Sloan Technical Support at: 1-888-SLOAN-14 (1-888-756-2614).

Installation Instructions for GEM•2®

EBV-157-A Handle Adapter Kit

When converting a GEM•2® manual flushometer to a Sensor Activated flushometer with an SMO (Side Mount Operator), an EBV-157-A Handle Adapter kit must be used.

1. Remove handle assembly from flushometer.
2. Place Green "L" gasket over the hub in the SMO connection area.

