

SloanStone® ELGR-80000 Sink

ELGR-81000

One Station Lavatory Systems

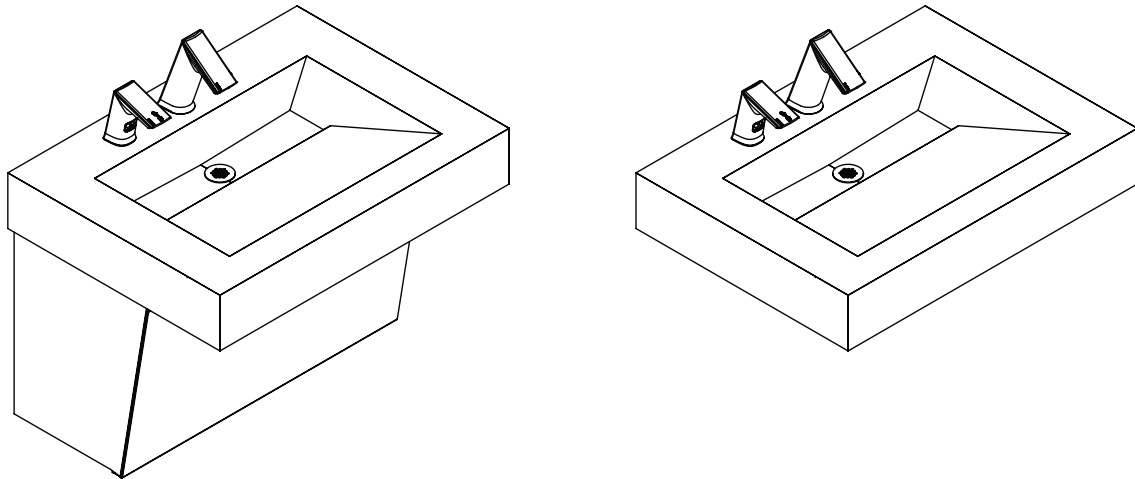

Sink Location

Determine the appropriate wall location for the Lavatory System. Consider that hot and cold water supply lines, a drain line, and an electrical source (receptacle for hardwired faucets and hand dryer) will be required. Compare the physical dimensions of the Lavatory System to the space available for the installation. If wall is not load bearing, a carrier may be required behind the wall. Refer to the appropriate Rough-in diagrams for Lavatory System dimensions. Prior to Lavatory System installation, electric wiring, water supply and drain must be installed.

ELGR-81000, One Station Components

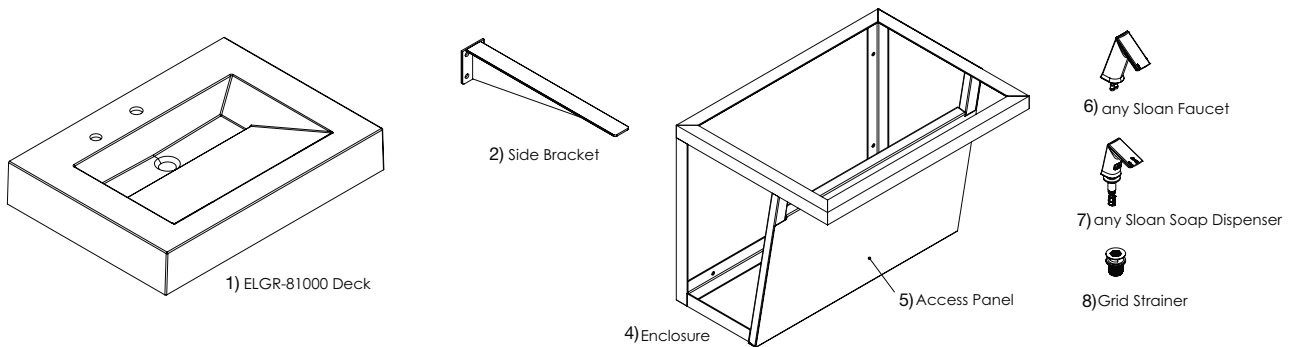

Note:
Faucet and soap dispenser models shown for reference, actual units will depend on what was selected at order entry.

ELGR-81000, One Station Component List

Description	Item Number	Quantity
Designer Series ELGR, One Station, Deck	1	1
Side Bracket (Mounting Option, 0386063)	2	2
Middle Bracket (Mounting Option, 0386064, not required for single station)	3	-
Angled Enclosure (Mounting Option)	4	1
Hook and Hang Access Panel	5	1
any Sloan Faucet	6	1
any Sloan Soap Dispenser Note: If ESD-500 Selected – Area under the sink must be clear for proper installation access and soap bottle change (no outlets, stops, etc).	7	1

SloanStone® ELGR-80000 Sink

ELGR-82000

Two Station Lavatory Systems

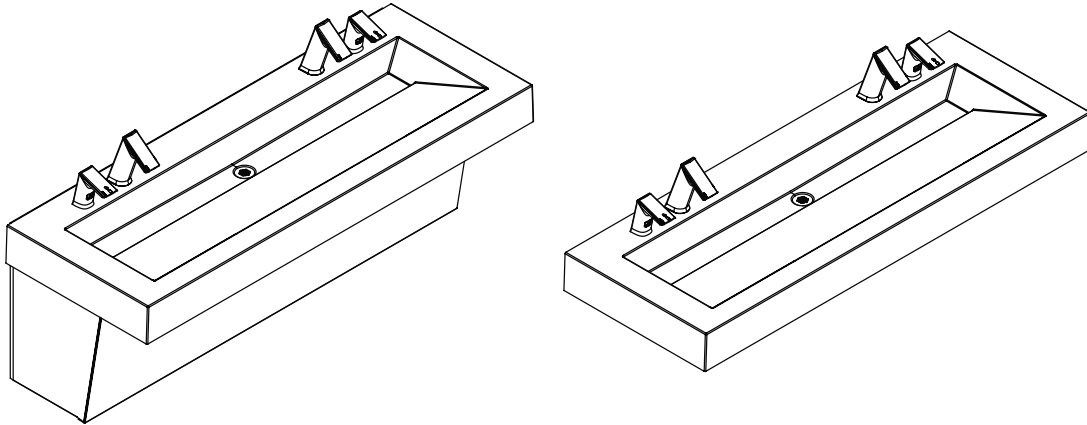

Sink Location

Determine the appropriate wall location for the Lavatory System. Consider that hot and cold water supply lines, a drain line, and an electrical source (receptacle for hardwired faucets and hand dryer) will be required. Compare the physical dimensions of the Lavatory System to the space available for the installation. If wall is not load bearing, a carrier may be required behind the wall. Refer to the appropriate Rough-in diagrams for Lavatory System dimensions. Prior to Lavatory System installation, electric wiring, water supply and drain must be installed.

ELGR-82000, Two Station Components

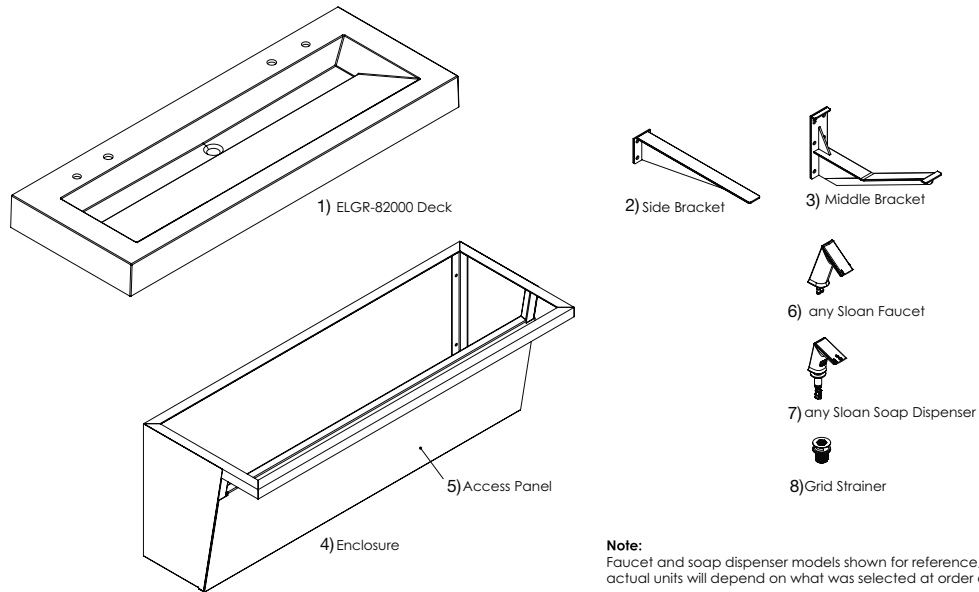

Note:
Faucet and soap dispenser models shown for reference, actual units will depend on what was selected at order entry.

ELGR-82000, Two Station Component List

Description	Item Number	Quantity
Designer Series ELGR, Two Station, Deck	1	1
Side Bracket (<i>Mounting Option, 0386063</i>)	2	2
Middle Bracket (<i>Mounting Option, 0386064</i>)	3	2
Angled Enclosure (<i>Mounting Option</i>)	4	1
Hook and Hang Access Panel	5	1
any Sloan Faucet	6	2
any Sloan Soap Dispenser Note: If ESD-500 Selected – Area under the sink must be clear for proper installation access and soap bottle change (no outlets, stops, etc).	7	2
Grid Strainer	8	1

SloanStone® ELGR-80000 Sink

ELGR-83000

Three Station Lavatory Systems

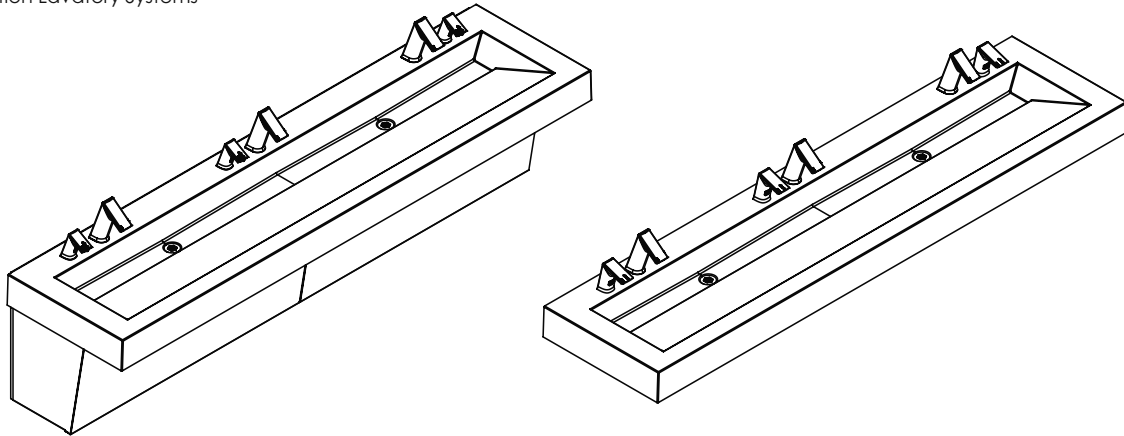

Sink Location

Determine the appropriate wall location for the Lavatory System. Consider that hot and cold water supply lines, a drain line, and an electrical source (receptacle for hardwired faucets and hand dryer) will be required. Compare the physical dimensions of the Lavatory System to the space available for the installation. If wall is not load bearing, a carrier may be required behind the wall. Refer to the appropriate Rough-in diagrams for Lavatory System dimensions. Prior to Lavatory System installation, electric wiring, water supply and drain must be installed.

ELGR-83000, Three Station Components

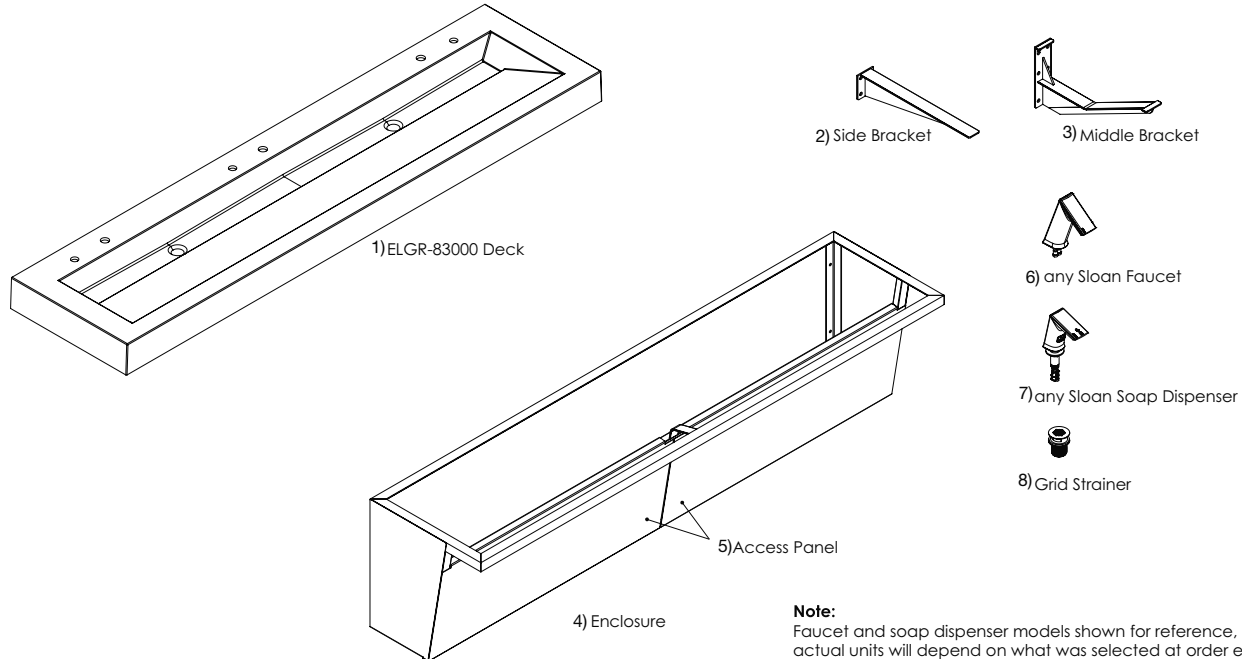

ELGR-83000, Three Station Component List

Description	Item Number	Quantity
Designer Series ELGR, Three Station, Deck	1	1
Side Bracket (Mounting Option, 0386063)	2	2
Middle Bracket (Mounting Option, 0386064)	3	4
Angled Enclosure (Mounting Option)	4	1
Hook and Hang Access Panel	5	2
any Sloan Faucet	6	3
any Sloan Soap Dispenser Note: If ESD-500 Selected – Area under the sink must be clear for proper installation access and soap bottle change (no outlets, stops, etc).	7	3
Grid Strainer	8	2

SloanStone® ELGR-80000 Sink

ELGR-84000

Four Station Lavatory Systems

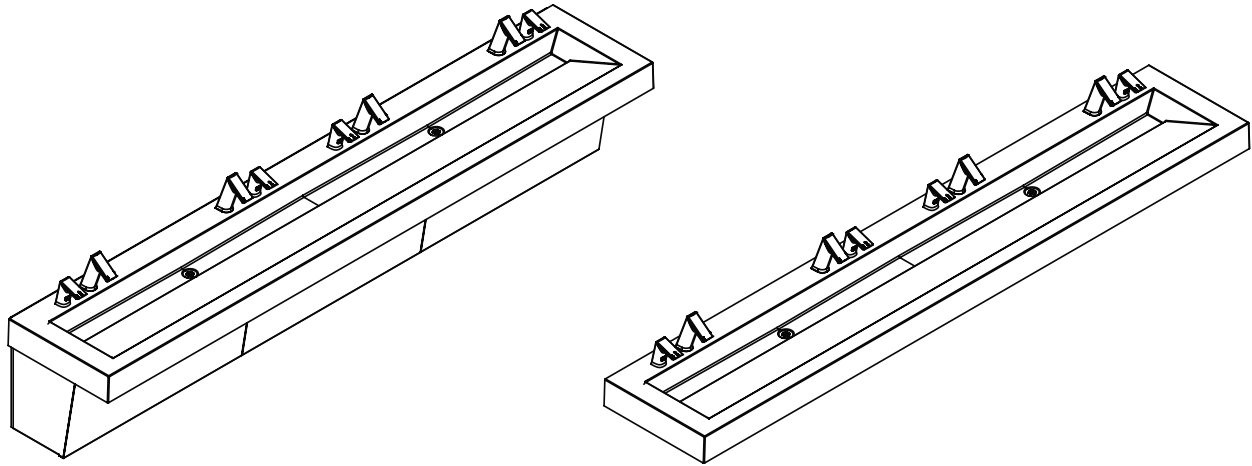

Sink Location

Determine the appropriate wall location for the Lavatory System. Consider that hot and cold water supply lines, a drain line, and an electrical source (receptacle for hardwired faucets and hand dryer) will be required. Compare the physical dimensions of the Lavatory System to the space available for the installation. If wall is not load bearing, a carrier may be required behind the wall. Refer to the appropriate Rough-in diagrams for Lavatory System dimensions. Prior to Lavatory System installation, electric wiring, water supply and drain must be installed.

ELGR-84000, Four Station Components

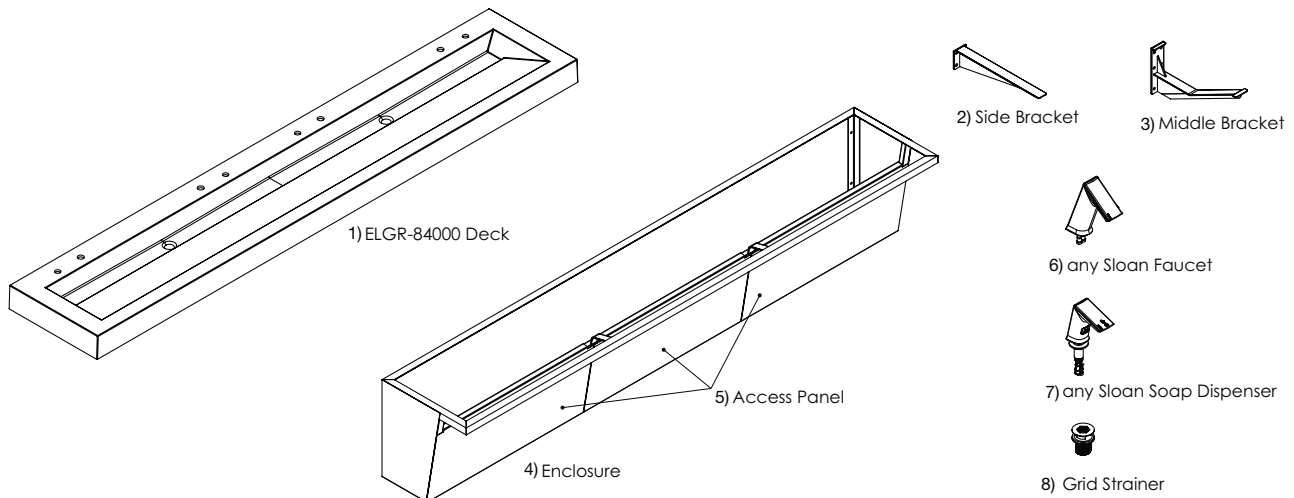

Note:

Faucet and soap dispenser models shown for reference, actual units will depend on what was selected at order entry.

ELGR-84000, Four Station Component List

Description	Item Number	Quantity
Designer Series ELGR, Four Station, Deck	1	1
Side Bracket (Mounting Option, 0386063)	2	2
Middle Bracket (Mounting Option, 0386064)	3	6
Angled Enclosure (Mounting Option)	4	1
Hook and Hang Access Panel	5	3
any Sloan Faucet	6	4
any Sloan Soap Dispenser Note: If ESD-500 Selected – Area under the sink must be clear for proper installation access and soap bottle change (no outlets, stops, etc).	7	4
Grid Strainer	8	2

SloanStone® ELGR-80000 Sink

TROUBLESHOOTING GUIDE

Refer to appropriate faucet pages in Maintenance Guide.

1. No water flows when sensor is activated

Ensure that main power supply is turned "ON." Check receptacle, transformer, batteries (battery powered models), solenoid, leads and connections.

INDICATOR: If Sensor LED does not blink:

- A. Control module circuit board is faulty; replace.
- B. Sensor is faulty; replace sensor module.

INDICATOR: If Sensor LED blinks when user is sensed:

- A. Supply Stop(s) may be closed; open Supply Stop(s).
- B. Debris may be in Solenoid filter; remove, clean and reinstall.

2. Very low flow or slow dribble

- A. Supply Stop(s) may be closed; open Supply Stop(s).
- B. Debris is in solenoid, won't close properly; remove operator and clean. Reassemble in the same manner.
- C. Debris may be in Solenoid filter; remove, clean and reinstall.
- D. Debris is in aerator; remove, clean and reinstall.

3. Continues to run (even after power to faucet has been disconnected)

- A. Solenoid valve is installed backwards; install correctly.
- B. Debris is in solenoid, won't close properly; remove operator and clean. Reassemble in the same manner.

Solenoid Screen Filter Cleaning

- A. Before cleaning the Screen Filter, turn off the water supply at supply stop(s).
- B. Activate the Faucet to relieve any pressure in the system.
- C. Unscrew the Filter Cap and remove it from the Solenoid Valve Housing.
- D. Carefully remove the Screen Filter from the Solenoid Valve Housing.
- E. Clean the Screen Filter using fresh tap water only. If necessary, use a small brush to clean.
Use caution while cleaning to prevent damage to Screen Filter.
- F. Examine the Copper Washer or O-ring for wear or damage; replace if necessary. Carefully replace the Screen Filter into Filter Cap. Screw the Filter Cap with Copper Washer or O-ring into Solenoid Valve Housing and tighten securely to prevent leaks.
- G. Turn on the water supply at the supply stop(s). Activate the Faucet to purge any air from the system lines. Check for leaks and repair as necessary.

SloanStone® Solid Surface Care

For normal cleaning, use warm, soapy water or conventional ammonia based liquid glass cleaner.

For dry stains, allow the soapy water or glass cleaner some time to re moisturize the area, then wipe the stain off.

To renew the surface after deep scratches or stains, use green, then maroon, and finally white 3M Scotch-Brite® pads to return the deck to a smooth 1200 grit wet-sanded finish.

If the dry stain is neither water-based nor oil-based, gently scrape the stain off with a plastic material (i.e. a plastic knife), and then proceed with the aforementioned normal cleaning procedures.

Wipe the entire surface evenly with a mild abrasive cleanser for regular maintenance.

**When assistance is required, please contact
Sloan Technical Support at: 1-888-SLOAN-14 (1-888-756-2614).**